

政鈺機械股份有限公司
GMA MACHINERY ENTERPRISE CO., LTD.

FILM DIE LAMINATION DIE

フィルムダイス
ラミネットダイス



薄膜以及淋膜模具系列 Film & Lamination Die

薄膜與淋膜製程多半應用於各類型的包裝,阻絕,印刷等,涵蓋食品,光學,醫藥等產業。
Mostly usage of film and lamination process are for various of package application, such like as optical barrier, print, food package and medical package etc.

政鈺薄膜模具可用於CPP,雙向延伸,光學膜,阻隔膜以及PET收縮膜等產線上,淋膜模具提供CFJ/CFC不同設計形式,可淋於膜,紙,編織袋等底材。

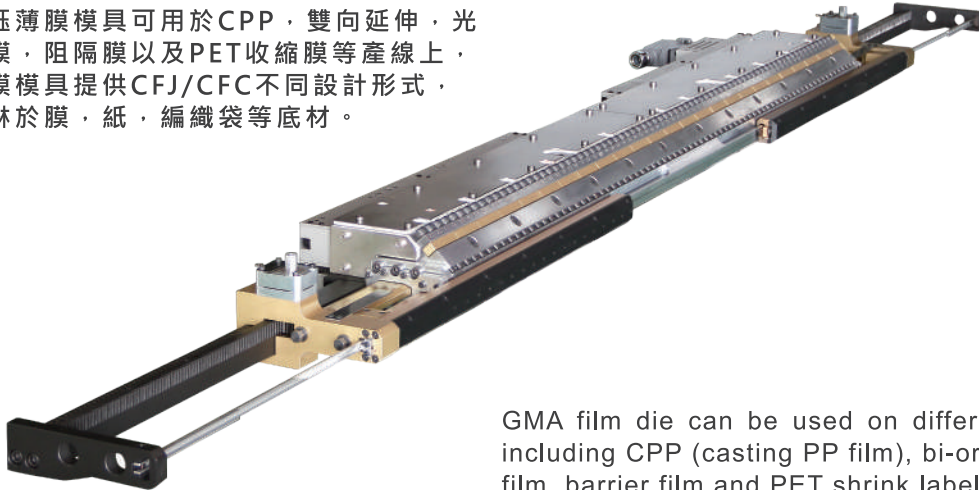

GMA film die can be used on different production lines, including CPP (casting PP film), bi-orientation film, optical film, barrier film and PET shrink label film etc.
GMA provides different design of lamination die to meet customer requirement, for coating on film, paper or raffia.

為滿足多元化的應用需求,此系列模具以特殊鏡面加工與研磨處理,模內成形段粗糙度可達 Ra0.01 um,確保表面無加工痕跡,搭配多種寬度與厚度線上調整系統,同時針對淋膜模具特別設計的免修邊與快速換料,可有效提升生產效率,確保生產品質。

For meeting various application, improving production efficiency and ensuring good quality product, GMA has special mirror processing and fine grinding for film and lamination dies surface, the roughness of landing area is Ra0.01um, without processing mark on surface, meanwhile, GMA provides various of on-line width adjustment and thickness adjustment device as option, free edge and fast change polymer design are special for lamination die.

薄膜模具本體結構 Film die structure

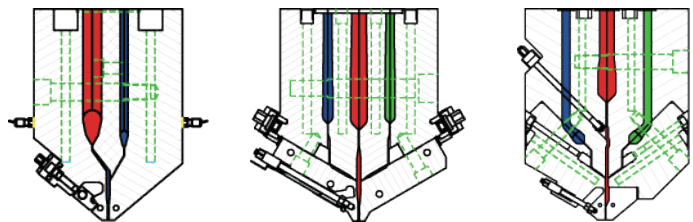

- 可選擇二層複合、三層複合、五層複合的設計
- 獨立幾何流道設計,提供最佳層與層複合介面
- 黏度差異大、流速差異大,可搭配流量調節閥設計
- 層與層之間塑料溫差大仍可完美結合的特殊隔熱設計
- 每轉0.25mm調整量的調整螺絲,是用厚薄差要求更嚴苛的產品
- Two-layer, three-layer, and five-layer multi-manifold design.
- Independent geometry manifold design provides the best co-extrusion interface.
- Viscosity difference, flow rate difference, can be used with flow control valve design.
- Thermal insulation design for big range resin temperature difference between layers is still perfectly integrated.
- 0.25mm adjustment screw per turn, apply to more severe product thickness requirements.

自動控制器系統

Automatic Control System

模具加裝自動控制螺栓，將模具由原先手動調整厚薄升級為自動調整厚薄，透過與測厚儀監測與連線控制，能夠協助在長時間的連續生產過程中及時精準控制製品的厚薄，減少不良品比率，節省調整工時，大幅提升製品品質。

Once the die is equipped with our automatic control system, the thermo bolts will synchronize with the thickness gauging system. The automatic system will do the fine tuning of the die gap. It will help to reduce the tuning time and defect loss greatly, especially for long time production control.



淋膜模具本體結構 Lamination die structure CFC / CFJ

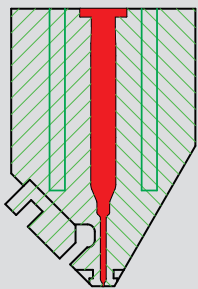

CFC

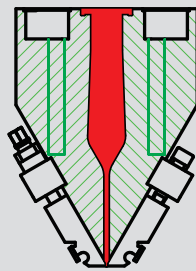

CFJ

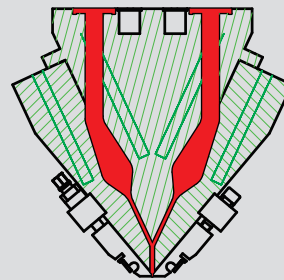

2 layers

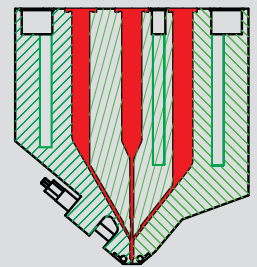

3 layers

multi-manifold structure

	CFC	CFJ
結構 Structure	兩片式結構 Two piece 可加裝自動控制器 Automatic system is available	四片結構, 分離式模唇 Four piece, lip and die body are separately
流道 Channel	T 型或 衣架型 T-channel / coat hanger	T型流道設計 T-Channel
塞料系統 Deckling system	內塞 Inner deckle	內塞 Inner deckle

氣泡布模具

bubble wrap die

氣泡布多用於包裝緩衝材，政鈺氣泡部模具可配合客戶產線規劃需求，採用二組或三組模具組成，或是由單一模具生產，獨特的內部流道設計以及出料設計，確保出料均勻，讓氣泡布在成型過程中保持高度良率，避免原料耗損。

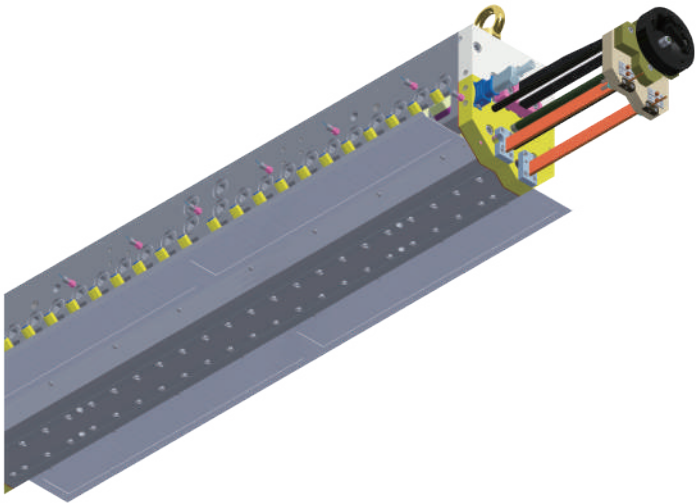

Bubble wrap is mostly applied for buffer package, GMA cam meet bubble production line design, equips with two or three dies, even though one special design bubble wrap die. Unique inner channel and exit design, ensure polymer to be even from lip, to keep high percentage yield of bubble wrap forming, save polymer.

模唇調整 Lip Adjustment

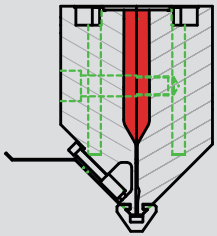

只壓不拉模唇調整螺絲
Push only

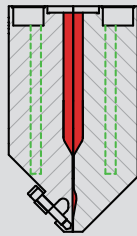

一壓一拉模唇調整螺絲
Push & Pull

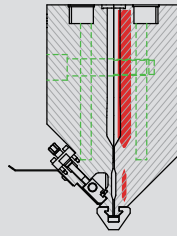

差速模唇調整螺絲
Differential

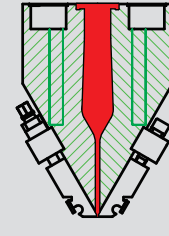

差速螺絲與一壓一拉
Differential and one push & pull

- 每轉1.25mm調整量
- 螺絲調整範圍2.0mm
- 適用於廣泛板類產線
- 可搭配外塞機構生產不同幅寬的產品
- 建議塞料寬不超過模寬1/4

- 1.25mm per rotation adjustment.
- Screw spacing 2.0mm.
- Apt for most sheet production lines.
- External deckle system for different width products.
- Deckle width should be within 1/3 slot width.

- 每轉0.5mm調整量
- 螺絲間距25mm
- 適用於多數板材生產線
- 可搭配外塞機構生產不同幅寬的產品
- 特定情況可選用內塞機構

- 0.5mm per rotation adjustment.
- Screw pitch 25mm.
- Apt for most sheet production lines.
- External deckle system for different width products.
- Internal deckle system available for specific spec..

- 差速螺絲每轉0.5mm
- 一壓一拉每轉1.25mm
- 螺絲間距25mm
- 兩種不同螺絲搭配使用可做較大範圍開口調整以及微調

- 0.5mm per rotation adjustment for differential screws.
- 1.25mm per rotation adjustment for one push & pull.
- Screw pitch is 25mm.
- Two different type screw can be used for wider lip gap adjustment and fine adjustmentd.

薄膜塞料調整機構 Deckle system for film die

手輪式內塞 inner deckle with hand wheel

可線上調整薄膜寬幅,手輪機構方便移動

on-line width adjustment is available, hand wheel is easy to be operated

電動式內塞 inner deckle with motor driven

更方便精確控制塞料機構,節省調整寬度時間

Motor drive is easier and accurate to operate deckle device, save adjustment time.

手輪式內塞 inner deckle with hand wheel

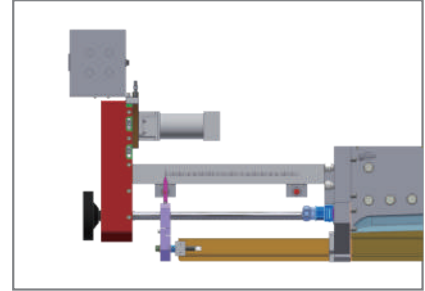
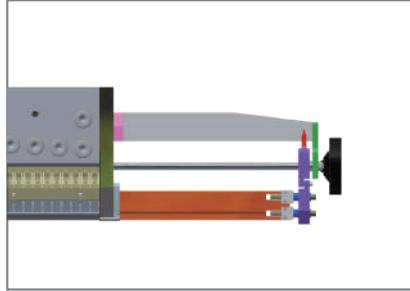
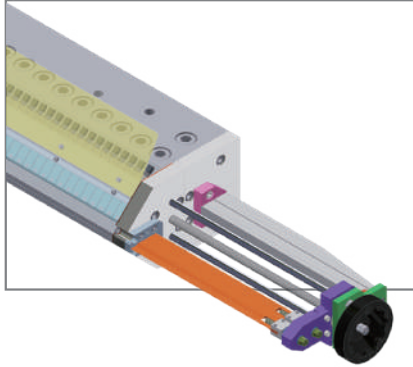

電動式內塞
inner deckle with motor driven

淋膜塞料調整機構 Deckle system for lamination die

手輪式內塞 inner deckle with hand wheel

- 可線上調整寬幅,方便操作
- 特殊塞料結構設計,減少修邊以及避免兩側漏料
- 換色快速,保養容易(僅限T型流道)

- on-line width adjustment is available, easy operation
- special components of deckle is for no edge-bean, and avoid from leakage from both side.
- easy and fast color change (only for T channel) and maintenance.

流道全封閉式線性滑軌內塞 Full channel inner deckle with linear slide

- 可線上調整寬幅,線性滑軌方式運行,省力好操作
- 塞料機構完整覆蓋流道,避免側邊漏料,確保膜腔內塑料流速均勻
- 此塞料系統可用於手動與自動模具上(僅限衣架型流道)

- on-line width adjustment is available, rapid operation.
- inner deckle components are full range surface contact to keep no leakage and ensure uniformity flow speed.
- for manual die or auto-die is available. (coat hanger channel only)

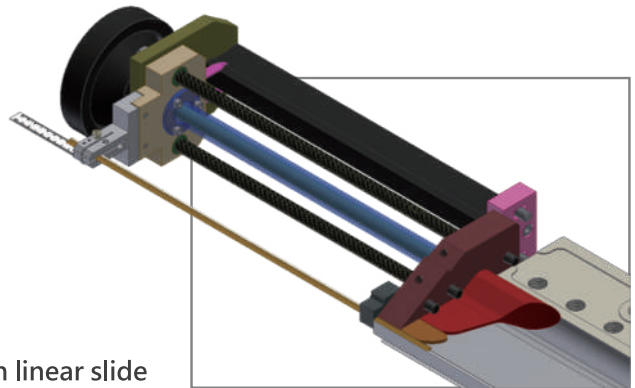

手輪式內塞
inner deckle with hand wheel

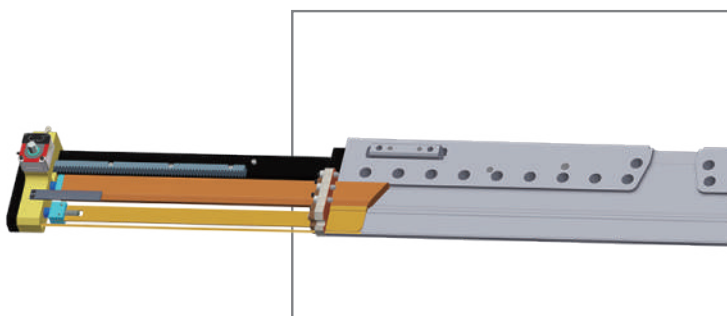

流道全封閉式線性滑軌內塞(手動模具)
Full channel inner deckle with
linear slide (manual die)

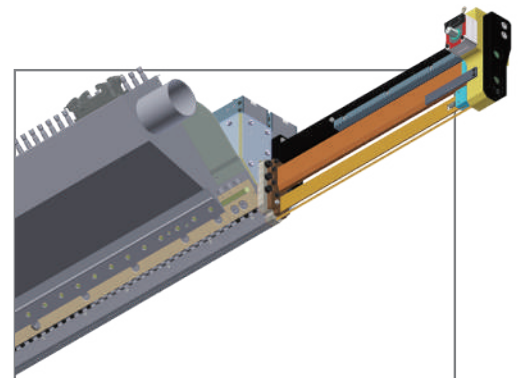

流道全封閉式線性滑軌內塞(自動模具)
Full channel inner deckle with
linear slide (auto-die)

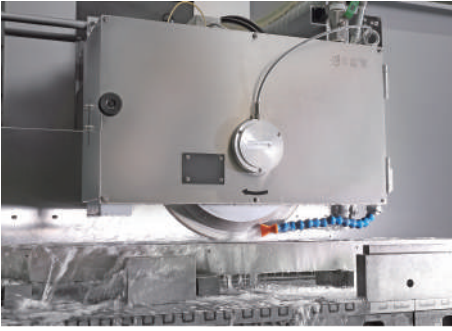

高精密加工製程 High Precision Machining

透過超精密研磨、拋光等加工，使流道表面不易沾黏，造成流痕，增加良率，提高光學板製品光滑與平坦。

The optical sheet is flat and smooth due to the high precision grinding, polishing, and machining on the extrusion dies.

適用原料 Suitable Polymer

薄膜 Film : PP, PE, EVA, PLA, PVC, APET, GPET, TPU

淋膜 Lamination: PP, PE, EVA, PLA, PBS

運用領域 Application

政鈺薄膜模具可用於CPP，雙向延伸，光學膜，阻隔膜以及PET收縮膜等產線上，淋膜模具提供CFJ/CFC不同設計形式，可淋於膜，紙，編織袋等底材。

GMA film die can be used on different production lines, including CPP (casting PP film), bi-orientation film, optical film, barrier film and PET shrink label film etc. GMA provide three design of lamination dies, such like CFJ and CFC , for coating on film, paper or raffia application.



產品規格 Product Specification	產品寬度範圍 Product Width	50~7000 mm
	產品厚度範圍 Product Thickness	0.15~50 mm
	適用押出量 Extrusion Capacity	1~3500 kg/hr

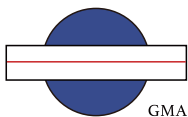

GMA 政鈺機械股份有限公司
GMA MACHINERY ENTERPRISE CO., LTD.



📍 43547台中市梧棲區永興路二段362巷28號 | No.28 Lane 362, Sec. 2, Yung Hsing Rd., Wu Chi Dist., Taichung

☎ +886-4-26303228

✉ info@gma.com.tw

☎ +886-4-26303208

🌐 www.gmatw.com